

May 11, 1948.

J. KIRCHHOF

2,441,156

LOCOMOTIVE VALVE ARRANGEMENT

Filed March 6, 1944

3 Sheets-Sheet 1

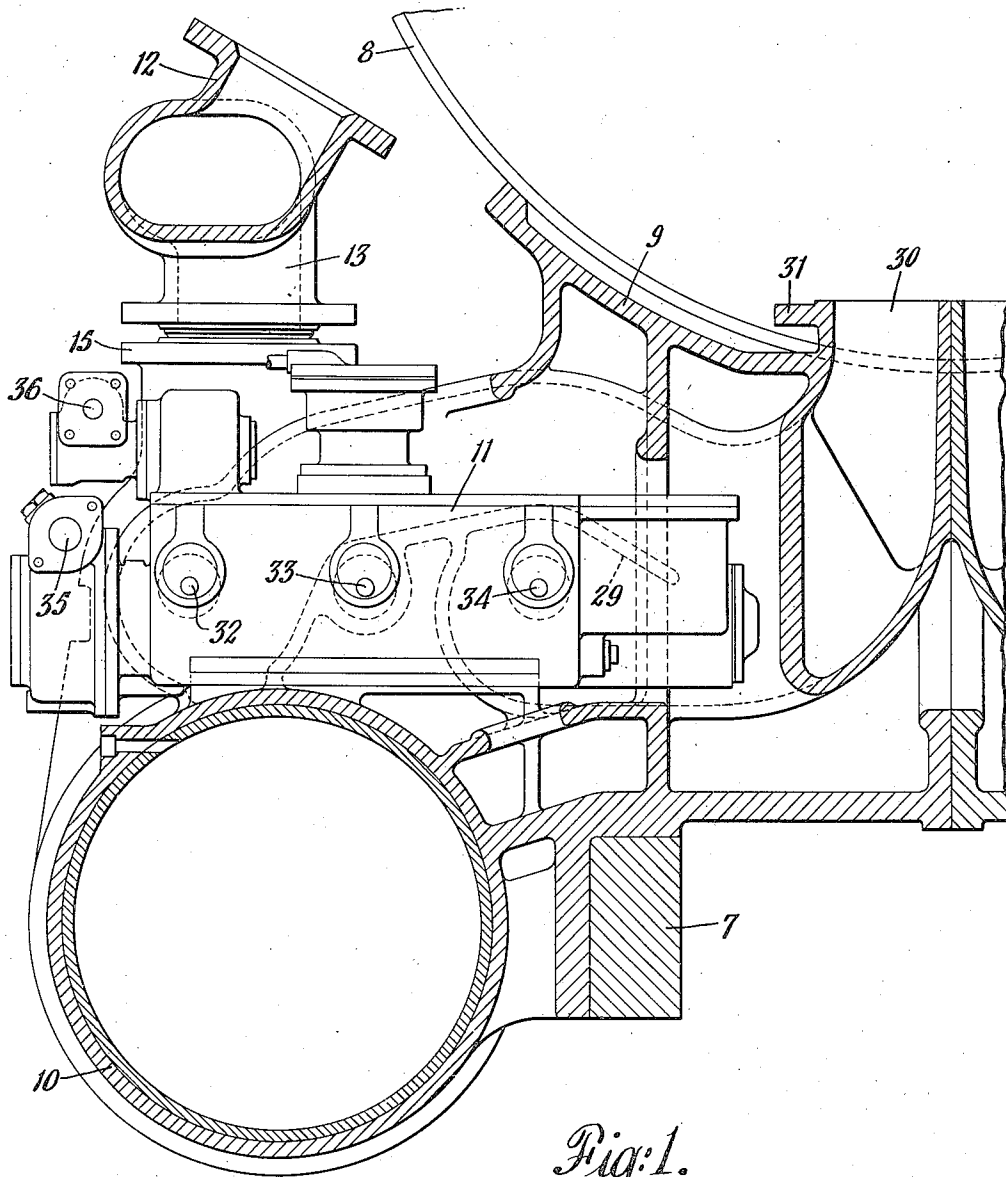

Fig. 1.

INVENTOR.
Julius Kirchhof
BY
Seymour & Lehner
ATTORNEYS

May 11, 1948.

J. KIRCHHOF

2,441,156

LOCOMOTIVE VALVE ARRANGEMENT

Filed March 6, 1944

3 Sheets-Sheet 2

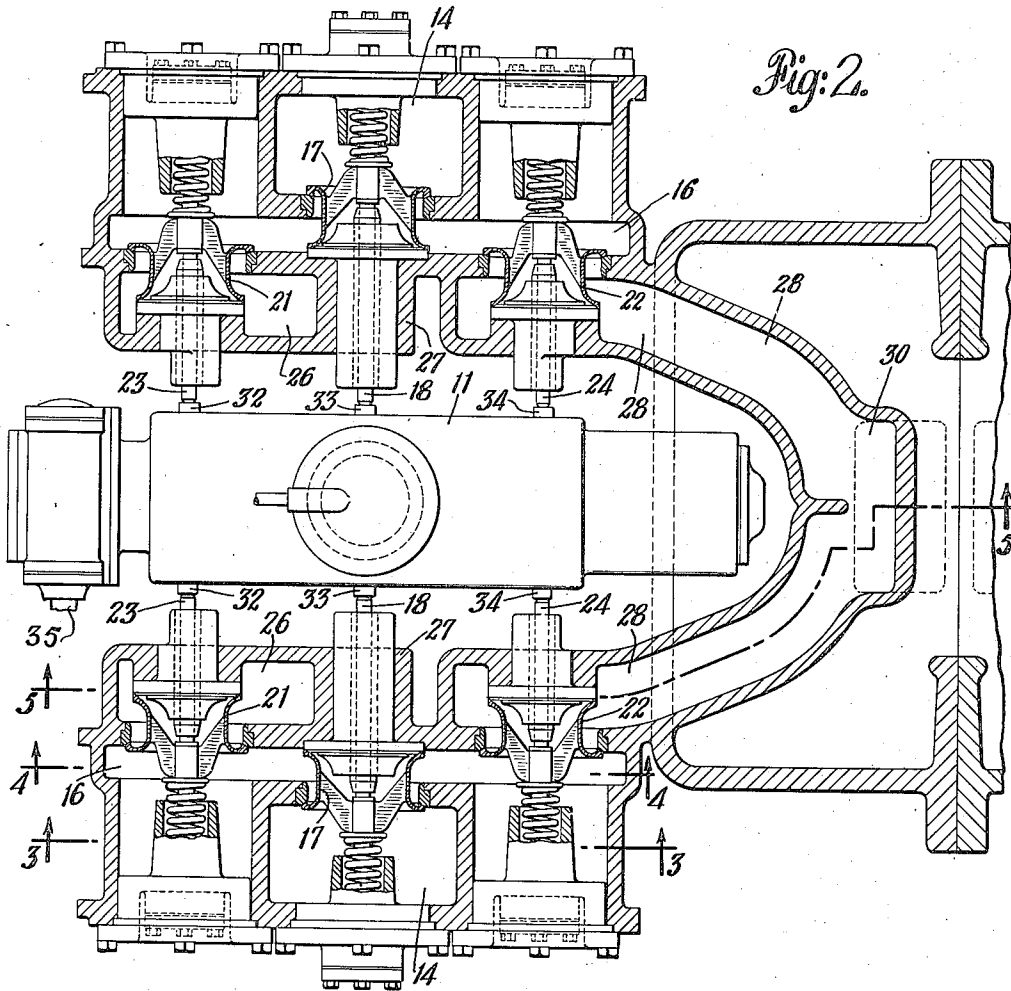

Fig. 2.

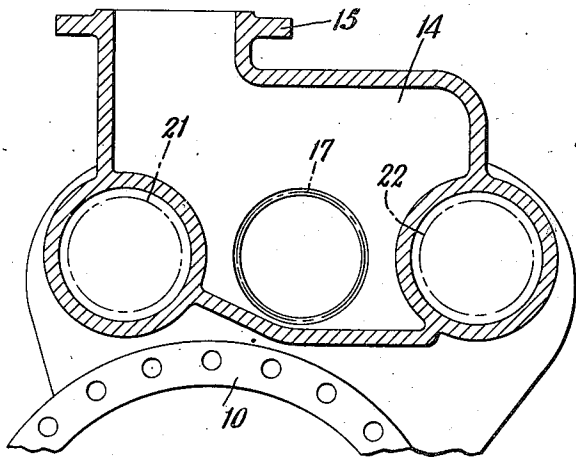

Fig. 3.

INVENTOR.
BY *Julius Kirchhof*
Symon & Lehman
ATTORNEYS

May 11, 1948.

J. KIRCHHOF

2,441,156

LOCOMOTIVE VALVE ARRANGEMENT

Filed March 6, 1944

3 Sheets-Sheet 3

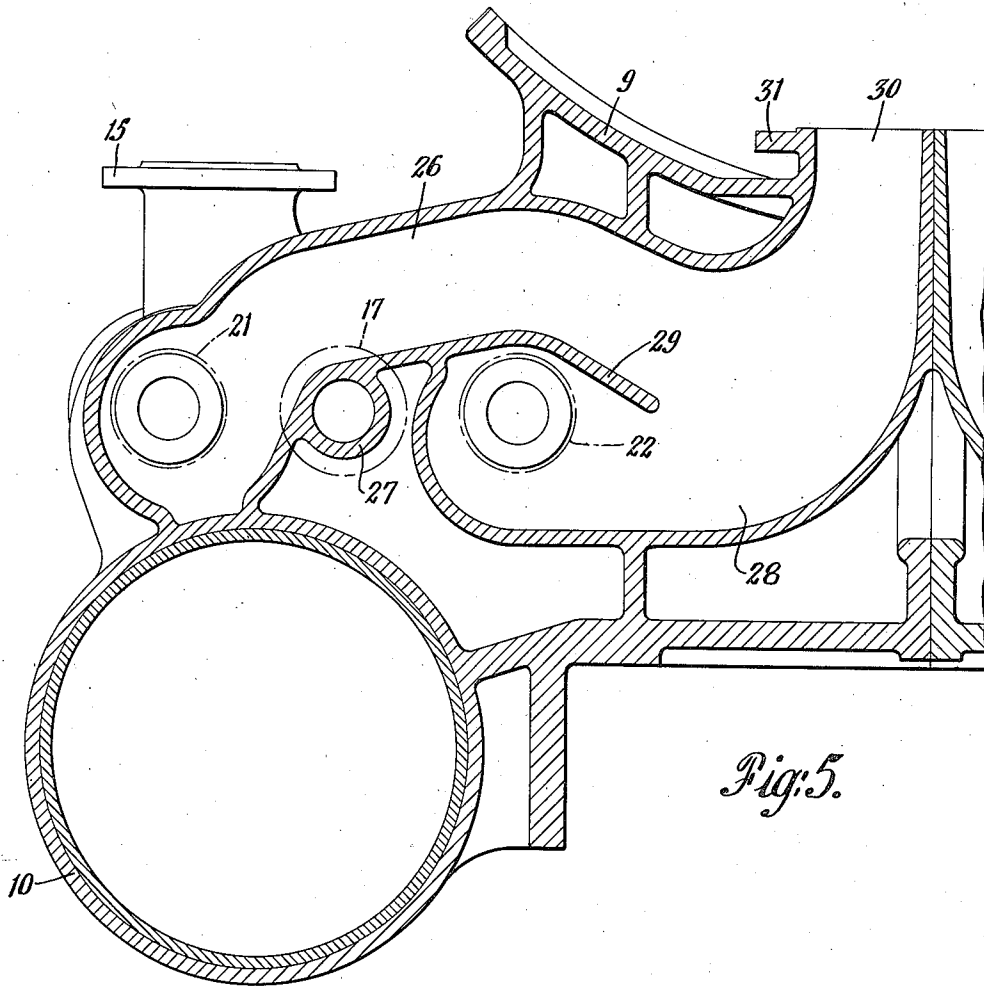

Fig. 5.

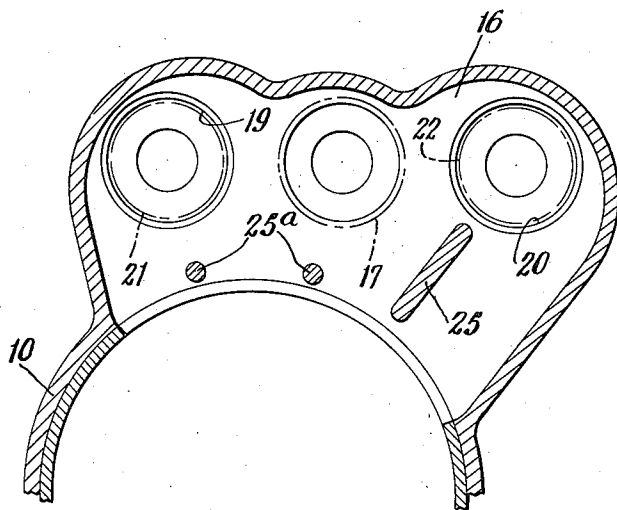

Fig. 4.

INVENTOR.
BY *Julius Kirchhof*
Symon & Schmitt
ATTORNEYS

UNITED STATES PATENT OFFICE

2,441,156

LOCOMOTIVE VALVE ARRANGEMENT

Julius Kirchof, Ruxton, Md., assignor, by mesne assignments, to Franklin Railway Supply Company, New York, N. Y., a corporation of Delaware

Application March 6, 1944, Serial No. 525,182

8 Claims. (Cl. 105—44)

1

This invention relates to poppet valve steam distributing mechanism for locomotive engines, and is especially concerned with a novel arrangement of the poppet valves and of the associated intake and exhaust steam passages.

One of the objects of the invention is to provide an arrangement of valves and associated steam passages so located and relatively positioned as to bring the valves and thus also the valve actuating mechanism well inwardly from the sides of the locomotive. In this connection it may be noted that the valves for each cylinder are adapted to be actuated by a cam mechanism which is conveniently mounted above the cylinder intermediate the sets of valves which are located toward opposite ends of the cylinder. Since the valves, according to the invention, are brought relatively close to the longitudinal vertical mid-plane of the locomotive, the associated cam actuating mechanism may also be brought close to the center plane, thereby avoiding projection of the cam box and even permitting the disposition of cam operating and controlling connections at the outer end of the cam mechanism, without exceeding clearance limitations.

According to an important aspect of the invention, the valves for each end of each cylinder are arranged in a manner so that intake and exhaust valves are positioned adjacent to each other on centers which are relatively closely coupled. In fact valves of the two types, according to the invention, are advantageously brought so close together that the normal required flow areas around the valves overlap. Since steam flow does not take place through intake and exhaust valves at the same moment, a given volume in the steam passages may be utilized to provide the normal required flow area for adjacent intake and exhaust valves, notwithstanding the fact that the patterns of the required flow areas actually overlap.

According to the preferred arrangement, a set of three valves is arranged in the steam chest at each end of each cylinder, the valves in each chest including two exhaust valves and one intake valve, the axis of the latter being positioned in a longitudinal vertical plane which is intermediate vertical planes containing the two exhaust valve axes, and preferably also in a common horizontal plane with both of the exhaust valves. The location of one type between a pair of valves of the other type is of advantage for reasons above mentioned, including the fact that the three valves may be grouped more closely without interference with the normal required steam flow

2

areas surrounding the valves, than is possible where two valves of the same type are located next to each other.

Moreover, with the three valves located in a common horizontal plane, the cam actuating mechanism for the set of valves at each end of each cylinder may correspondingly be arranged in a common horizontal plane. As will be understood by those skilled in the art this enables appreciable simplification of the cam actuating mechanism, as compared with an arrangement in which the valves are arranged at different heights above the cylinder.

The three valves of each set (arranged in a common horizontal plane with the intake valve in the middle) are, as a group, positioned asymmetrically with reference to a vertical plane containing the axis of the associated cylinder. Specifically, the set of valves as a whole, lies in major part toward the inner side of the vertical plane containing the cylinder axis. This is of importance from the standpoint of avoiding excessive outward lateral projection either of the steam chest, of the associated cam mechanism, or of the actuating and control connections connected with the latter.

How the foregoing objects and advantages are attained will appear more fully from the following description referring to the accompanying drawings in which:

Figure 1 is a transverse vertical sectional view (looking forwardly) taken through the left cylinder and saddle casting of a 2-cylinder engine, the figure showing in elevation a cam actuating mechanism above the cylinder and also illustrating the disposition of certain of the exhaust passages;

Figure 2 is a horizontal sectional view through the cylinder and saddle casting taken in the plane of the valves;

Figure 3 is a transverse vertical sectional view taken in the plane of the intake steam connection, as indicated by the section line 3—3 on Figure 2;

Figure 4 is a view similar to Figure 3 but taken through a cylinder port as indicated by the line 4—4 on Figure 2; and

Figure 5 is a vertical sectional view illustrating particularly the exhaust steam passages, the view being taken as indicated by the line 5—5 on Figure 2.

In Figure 1 a main frame member of the locomotive appears at 7, the outline of the boiler being shown at 8. The cylinder and saddle casting includes a saddle structure 9 for support of

the boiler, the casting further including valve chests and steam passages, as well as the cylinder 10 (the left cylinder). A similar complementary casting is provided for the right side, or alternatively the entire saddle and both cylinders may be cast as a unit or as a part of the entire engine bed. A cam box incorporating cam actuating mechanism for the valves at both ends of cylinder 10 is arranged above the cylinder, the outline of this cam box being shown at 11.

The live steam pipe 12 is provided with branches 13 extending toward opposite ends of the cylinder and each branch 13 communicates with a live steam chamber at the corresponding end of the cylinder, such a chamber being shown at 14 in Figures 2 and 3. As seen in Figure 3 the chamber is provided with a flanged connection 15 for attachment to the branch pipe 13. The admission of steam from the chamber 14 to the cylinder port 16 and from there to the end of the cylinder is controlled by a poppet valve 17 shown in Figure 2, this valve having a stem 18 adapted to be actuated by the cam mechanism in the cam box 11. As clearly appears in the vertical sectional view of Figure 4, the cylinder port 16 communicates with the end of the cylinder over a substantial portion of the circumference thereof. Figure 4 also shows the openings 19 and 20 for the exhaust valves 21 and 22 which are shown in Figure 2, these valves also having stems 23 and 24 adapted to be actuated by the cam mechanism.

The relative position of the three valves in each set clearly appears in several of the figures, in which connection it is noted that the three valves all lie substantially in a common horizontal plane, the intake valve being disposed between the two exhaust valves, and the entire group being located well inwardly from the outside edge of the cylinder. Thus it will be noted that the valves are so disposed that a vertical plane containing the axis of the cylinder passes approximately midway between the outer exhaust valve opening 19 and the intake valve. Note from Figure 4 that an integral brace 25 is arranged between the front and rear walls which define the cylinder port 16 in the region between the exhaust valve opening 20 and the cylinder. This brace or web, and also the stays 25a-25a are of importance in interbracing the vertical walls defining the cylinder port, and thereby acting to reduce warpage at the valve seats.

The arrangement of the exhaust steam passages is best seen in Figures 2 and 5. As there shown, one exhaust passage 26 extends from the outer exhaust valve 21 upwardly and over the cylindrical supporting wall 27 for the intermediate intake valve. Note particularly that the arrangement of the several valves permits this exhaust passage 26 to be extended inwardly at a low angle and thus more directly toward the point of discharge, without requiring sharp bends which is of importance in avoiding power losses. Another passage 28 cooperates with the exhaust valve 22 and extends inwardly therefrom, the two exhaust passages 26 and 28 being vertically separated from each other by a partition wall 29 which terminates at a point somewhat inwardly of valve 22, after which point the two exhaust passages join in a common passage 30 which extends inwardly and thence upwardly through the saddle structure, terminating in an end connection 31 adapted to cooperate with an exhaust nozzle or the like in the smokebox. The dividing wall 29 is of importance in avoiding flow of ex-

haust steam through passage 26 over the valve in passage 28, which flow might otherwise have a tendency to choke the inner exhaust valve.

Referring again to Figure 1 and also to Figure 2, attention is called to the fact that because of the arrangement of the three valves at each end of the cylinder in a common horizontal plane, the valve actuating tappets 32, 33 and 34 may be similarly arranged, thereby greatly simplifying the required cam actuating mechanism, an appropriate cam actuating mechanism for this purpose being disclosed in copending application of Julius Kirchoff and Raymond P. Delano, Jr., Serial No. 525,180 filed concurrently herewith. It may here be noted that continuously rotating cams are conveniently employed with a valve arrangement of the type herein disclosed, all three actuating cams being mounted on a common rotating shaft.

Examination of Figures 1 and 2 also shows that the cam box is located well inwardly, in view of which the driving shaft 35 and the reversing and cut-off control connection 36, including their gear-boxes 35a, 36a, may conveniently be located at the outer end of the cam box for convenience in removing the connections. For specific details of the arrangement of the parts just described, reference may be had to the copending application mentioned just above.

I claim:

1. In a locomotive engine equipped with poppet-type steam distributing valves, exhaust and intake valves arranged adjacent an end of a cylinder and comprising a group of at least three valves, one of which is for steam flow in one direction and the other two are for steam flow in the other direction, said two valves being located toward opposite sides of said one valve, and the axes of said three valves being located generally in a common transverse plane and the group of three being so closely grouped that the normal required flow area around each of said two valves overlaps that of the intermediate valve.

2. A construction in accordance with claim 1 in which said three valves, as a group, are asymmetrically disposed with relation to a vertical plane containing the axis of the cylinder, the center point of the group being offset inwardly from said plane.

3. In a locomotive engine equipped with poppet-type steam distributing valves, a group of three poppet valves arranged adjacent one end of a cylinder and comprising two exhaust valves and an intake valve, all three valves being located substantially in a common horizontal plane and the intake valve being disposed between the two exhaust valves, and further including an exhaust passage for the outer exhaust valve extended upwardly and inwardly over the intermediate intake valve, and an exhaust passage for the inner exhaust valve extended inwardly therefrom and joining the first exhaust passage generally in the same horizontal plane with the three valves at a point spaced appreciably inwardly of the inner exhaust valve.

4. In a locomotive engine equipped with poppet-type steam distributing valves, a cylinder and saddle structure having a cylinder toward one side of the locomotive and an exhaust steam discharge connection extended upwardly through the saddle, and a group of at least three poppet valves arranged adjacent one end of the cylinder and comprising at least one intake valve and at least two exhaust valves disposed at opposite sides of

5

an intake valve with associated exhaust steam passages extended therefrom to the discharge connection through the saddle, the axes of said three valves lying in spaced longitudinal vertical planes, and substantially in a common horizontal plane, and said three valves being so closely grouped that the normal required flow area around each of said two exhaust valves overlaps the flow area of the intake valve, and said three valves, as a group, being asymmetrically disposed with relation to a vertical plane containing the axis of the cylinder, with the center point of the group offset appreciably inwardly from the plane of the cylinder axis.

5. In a locomotive engine having poppet-type steam distributing valves, a group of at least three poppet valves arranged toward one end of a cylinder and including at least one intake valve and at least two exhaust valves with the axis of said intake valve located in a vertical plane between the vertical planes of the exhaust valve axes and with the two exhaust valves located substantially in a common horizontal plane spaced above the cylinder at least as far as the intake valve, an exhaust passage for the inner exhaust valve extended inwardly and upwardly therefrom, and an exhaust passage for the outer exhaust valve extended and inclined therefrom inwardly and upwardly at a low angle with reference to the plane of the exhaust valves at least to a point above the inner exhaust valve.

6. A construction in accordance with claim 5 in which the two exhaust passages join at a point spaced inwardly of the inner exhaust valve.

7. A construction in accordance with claim 5 in which the two exhaust passages join at a point spaced inwardly of the inner exhaust valve and

6

generally in the horizontal plane of the exhaust valves, the common exhaust steam passage thereafter being extended upwardly for discharge.

8. In a locomotive engine having a laterally-disposed cylinder, and poppet-type steam distributing valves, a group of at least three poppet valves arranged toward one end of said cylinder and including at least one intake valve and at least two exhaust valves with the axis of said intake valve located in a vertical plane between the vertical planes of the exhaust valve axes, and the axes of said three valves being in a common transverse plane, an exhaust passage for the inner exhaust valve extended inwardly and upwardly therefrom, and an exhaust passage for the outer exhaust valve extended and inclined therefrom inwardly and upwardly at least to a point above the inner exhaust valve.

JULIUS KIRCHHOF.

REFERENCES CITED

The following references are of record in the file of this patent:

UNITED STATES PATENTS

Number	Name	Date
298,194	Frisbie	May 6, 1884
909,665	Prescott	Jan. 12, 1909
1,671,821	Glaenzer et al.	May 29, 1928
1,697,097	Vanderhorst	Jan. 1, 1929
1,935,363	Kupka	Nov. 14, 1933

FOREIGN PATENTS

Number	Country	Date
1,384	Great Britain	May 10, 1867
396,437	Great Britain	Aug. 1, 1933